



Universal Drop-In Fuel Cell Pump Hangers

P/Ns 19-370, 19-380, 19-375, & 19-385

NOTE: Please read all instructions before proceeding with the installation of your new drop in fuel cell pump hanger. Failure to follow these instructions may result in poor performance, vehicle damage, personal injury, or death. If these instructions are not fully understood an installation should not be attempted. In this case, please contact Holley's tech service department or a qualified mechanic.

Parts Included:	
Qty.	Description
1	Fuel Pump Hanger Assembly
1	Gasket
1	Mounting Ring
6 - 12	Mounting Screws
6 - 12	Plastic Washers
2	Zip Ties
1	Fuel Pump Sock & lock ring

Tools Needed:
3/16 Hex Wrench
4mm Hex Wrench
Tape Measure
3/16 Drill Bit
1/4" Wrench

Tools Possibly Needed:
Metal Cutting Hole Saw
Vise
Pliers
1/4 inch Drill Bit

Parts Required for Installation:

- Post Pump Filter: Holley HP billet filter or equivalent. EFI systems should have a 10 micron or finer filter while carburetors should have a 40 micron or finer filter.
- Relay Kit (30amp min) – **Holley P/N 12-753** or equivalent
 - Additional wire and connectors may be necessary



Figure 1: Gasket being used as template to mark drilling locations



Figure 2: Measurement described in step 4.

Installing the Pump Hanger:

If your tank has a 6, or 12 bolt flange pre-drilled into it, then follow these instructions:

1. Use the gasket as a template to ensure that the mounting hole pattern is the same on the gasket as it is on the tank and that the center hole is the same diameter as the gasket. If either the mounting hole pattern or the center hole pre drilled in the tank does not match the gasket, then modify them so that they do.

NOTE: If the fuel cell has foam in it, the foam should be removed before any drilling or tank modification takes place. After modification has been completed, the tank should be thoroughly cleaned.

2. Again using the gasket as a template align the mounting holes and using a marker make a mark at the closed end of the two slots that extend from the center hole. **See Figure 1.**
3. Using a drill and a 3/16" drill bit drill two holes at the two marks you just made, these will be used later.

4. Using a tape measure, take a measurement through the center hole where the pump hanger assembly will be inserted to the mounting surface where the pump hanger flange will contact the tank. Record that measurement. **See Figure 2.**
5. Install the supplied fuel pump sock onto the pump by aligning it with the pump and the locating stud then pressing firmly to seat. Lock fuel pump sock onto fuel pump with supplied lock ring.
6. Take a measurement from the pump hanger flange to the top of the filter sock. If this measurement is longer than the measurement that was taken in step 4 then lower the pump until the two measurements are the same. If this measurement is shorter than the measurement taken in step 4 then raise the pump. **See Figure 3.**
 - a. To raise or lower the pump use a 4mm hex wrench to loosen the two screws used to clamp the pump mount onto the two stainless steel guide rods.
 - b. If the filter sock comes in contact with the guide rods but you still need the pump to go lower in order to have your two measurements match then the guide rods must be removed and broken at the break point that is milled into them.
 - i. Remove the guide rods from the pump flange.
 1. Loosen the two 4mm screws that retain the pump mount to the guide rods and slide the pump mount and pump assembly off of the rods.
 2. Using a 1/4" wrench or an adjustable wrench loosen the guide rods from the pump flange via the two flats at the base of the rods
 3. Place the short end of the rods in a vice and then grab the long end and push/pull the rods should break at the milled break point. **Shown in Figure 3.**
 - a. If it is difficult to break the rods then it may be necessary to get some extra leverage on the rods.
 - ii. Rebuild the pump assembly in the reverse order that it was taken apart and then continue matching the two measurements.
 1. Note: In certain cases it may be necessary to cut down the guide rods further
 7. Cut the return tube 1 inch shorter than the measurement taken in step 4 and then insert onto the return barb and fasten with the included hose clamp. **NOTE:** On returnless versions, skip this step.
 8. Take the included mounting ring and insert it into the fuel tank via the slot in the part. Then using the included zip ties, zip tie the mounting ring to the inside of the tank via the two small holes that were drilled in step 3. **See Figure 4.**

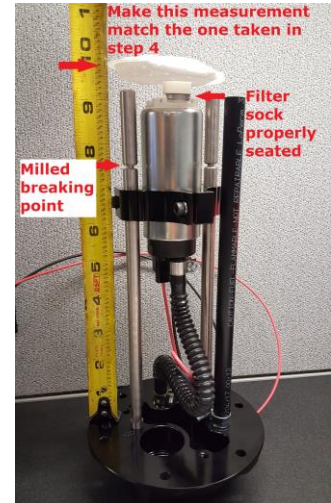

Figure 3: Example pump hanger assembly showing the measurement to be taken in step 6

Line up the gasket with the mounting holes and zip tie slots and then insert the fuel pump hanger assembly into the tank and fasten with the included mounting hardware using the plastic washers as gaskets for the mounting screws.

If your Fuel Cell does not have a 6, or 12 bolt flange drilled into it then follow the following instructions:

1. Determine the best place on the fuel cell surface to drill the center hole where the fuel pump hanger assembly will sit.



Figure 4: Mounting ring zip tie Locations

- a. 6 bolt flange units should use a 3 7/8" hole saw.
 - b. 12 bolt units should use a 4 1/2" hole saw
2. In determining where to drill the fuel cell consider
 - a. Finding a flat surface, in a central location.
 - b. Where the chassis frame rails contact the fuel tank.
 - c. Evaluating the position and path of the fuel level sender float – we recommend removing the existing unit to determine the float arm path and direction before cutting the new mount hole.
 - d. Locating any internal vent line routing
 - e. Avoiding any internal fuel bowls or baffles.
 - f. The best positioning possible for the supply, return hoses, wire harness, and vapor vent hose.
3. Once a determination has been made on where to drill, use the appropriate hole saw and drill the center hole in the cell. Make sure to deburr the inside and outside edges of the hole after drilling.
4. Using the supplied gasket as a template make marks at the center of all of the mounting holes as well as at the center of the closed ends of the slots that extend from the center hole. **See Figure 1**
5. Drill the mounting holes with a 1/4" drill bit and the slotted marks with a 3/16" drill bit then verify that all of the holes line up with the gasket. **See Figure 1**
6. Using a tape measure, take a measurement through the center hole where the pump hanger assembly will be inserted to the mounting surface where the pump hanger flange will contact the tank. Record that measurement **See Figure 2**
9. Install the supplied fuel pump sock onto the pump by aligning it up with the pump and then pressing firmly to seat. Lock fuel pump sock onto fuel pump with supplied lock ring.
7. Take a measurement from the pump hanger flange to the top of the filter sock. If this measurement is longer than the measurement that was taken in step 6 then lower the pump until the two measurements are the same. If this measurement is shorter than the measurement taken in step 6 then raise the pump. **See Figure 3**
 - a. To raise or lower the pump use a 4mm hex wrench to loosen the two screws used to clamp the pump mount onto the two stainless steel guide rods.
 - b. If the filter sock comes in contact with the guide rods, yet you still need the pump to go lower in order to have your two measurements match then the guide rods must be removed and broken at the break point that is milled into them.
 - i. Remove the guide rods from the pump flange.
 1. Loosen the two 4mm screws that retain the pump mount to the guide rods and slide the pump mount and pump assembly off of the rods.
 2. Using a 1/4" wrench or an adjustable wrench loosen the guide rods from the pump flange via the two flats at the base of the rods
 3. Place the short end of the rods in a vice and then grab the long end and push/pull the rods should break at the milled break point. **Shown in Figure 3**
 - a. If it is difficult to break the rods it may be necessary to get some extra leverage on the rods.
 - ii. Rebuild the pump assembly in the reverse order that it was taken apart and then continue matching the two measurements.
 1. Note: in certain cases it may be necessary to cut down the guide rods further
8. Cut the return tube 1 inch shorter than the measurement taken in step 4 and then insert onto the return barb and fasten with the included hose clamp. **NOTE:** On returnless versions, skip this step.
9. Take the included mounting ring and insert it into the fuel tank via the slot in the part. Then using the included zip ties zip tie the mounting ring to the inside of the tank via the two small holes that were drilled in step 3. **See Figure 4**
10. Line up the gasket with the mounting holes and zip tie slots and then insert the fuel pump hanger assembly into the tank and fasten with the included mounting hardware using the plastic washers as gaskets for the mounting screws.

Wiring your Fuel Pumps:

WARNING! USE A MINIMUM OF 12 GAUGE WIRE. BE SURE TO CRIMP OR SOLDER ALL CONNECTORS SECURELY AND CLEAN ANY AREA WHERE GROUND LEADS WILL BE FASTENED. FAILURE TO USE THE MINIMUM WIRE GAUGE COULD RESULT IN PUMP MALFUNCTION AND/OR ELECTRICAL FIRE, RESULTING IN PROPERTY DAMAGE, SERIOUS INJURY, AND/OR DEATH.

1. Disconnect the cables from the battery.
2. Mount relay/relays in convenient location away from exhaust heat.
3. Plug the fuel pump relay harness into the relay, until it locks into place.
4. Connect the black wire of the harness to ground.

NOTE: Be sure to route all electrical wires clear of any moving suspension or drivetrain components and any exhaust components! Protect wires from abrasion and road obstructions or debris.

If you have a Single DC pump (340 LPH), follow these instructions:

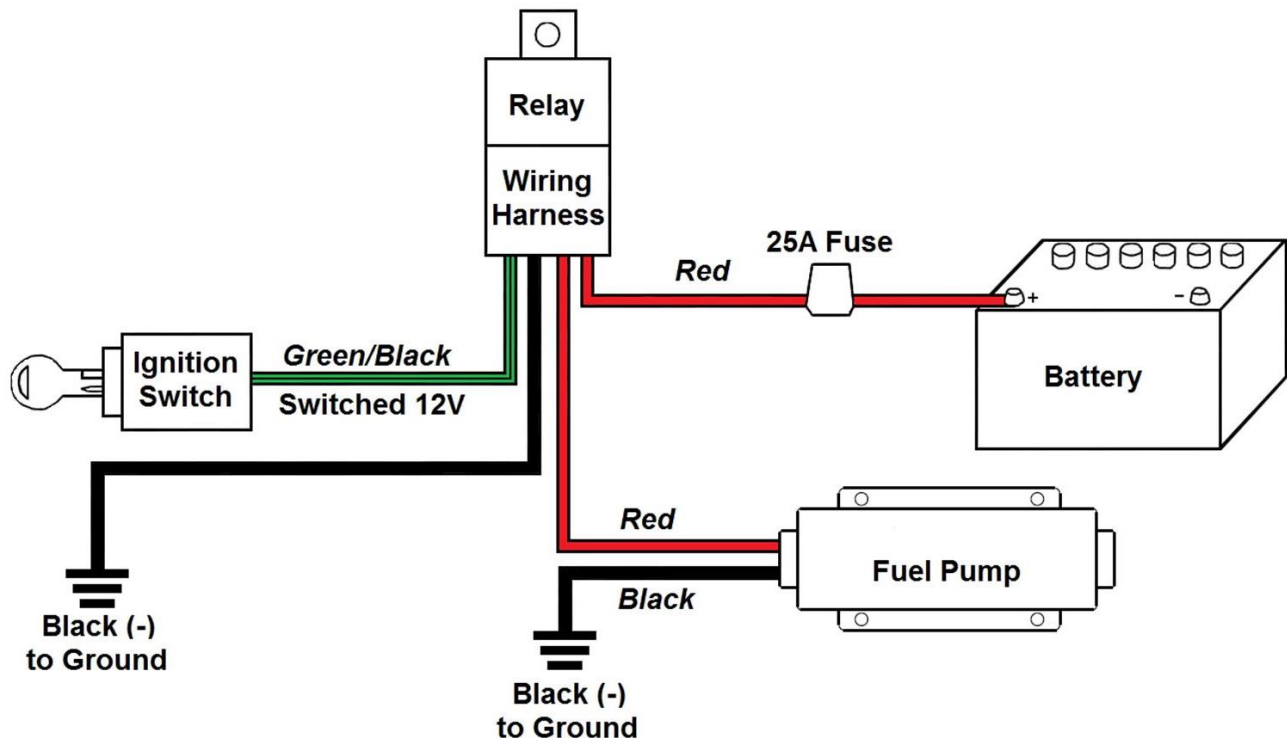

© 2018 Holley Performance Products. All Rights Reserved. Tous Droits Réservés.

199R11702

Date: 11-21-18